

LOC		DIST		REV		REVISIONS		DATE	APPD
CM	53	P	F	ZONE	LTR	DESCRIPTION		RV	RS
						N	REV PER EC 0730-0019-94	4-6-94	

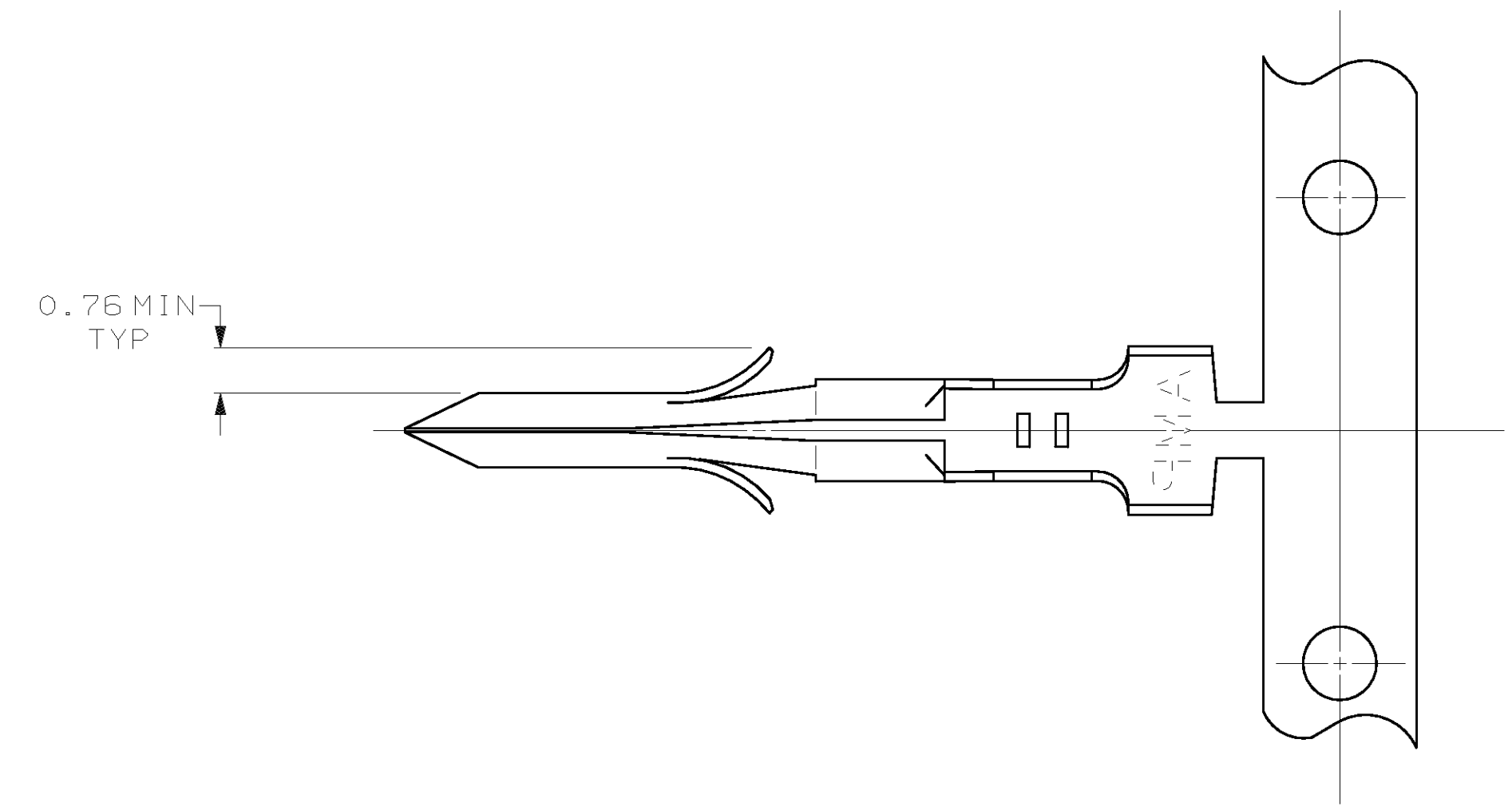

△ NICKEL OVER ENTIRE TERMINAL WITH 0.00076 THICK GOLD OVER 5.08 LENGTH.

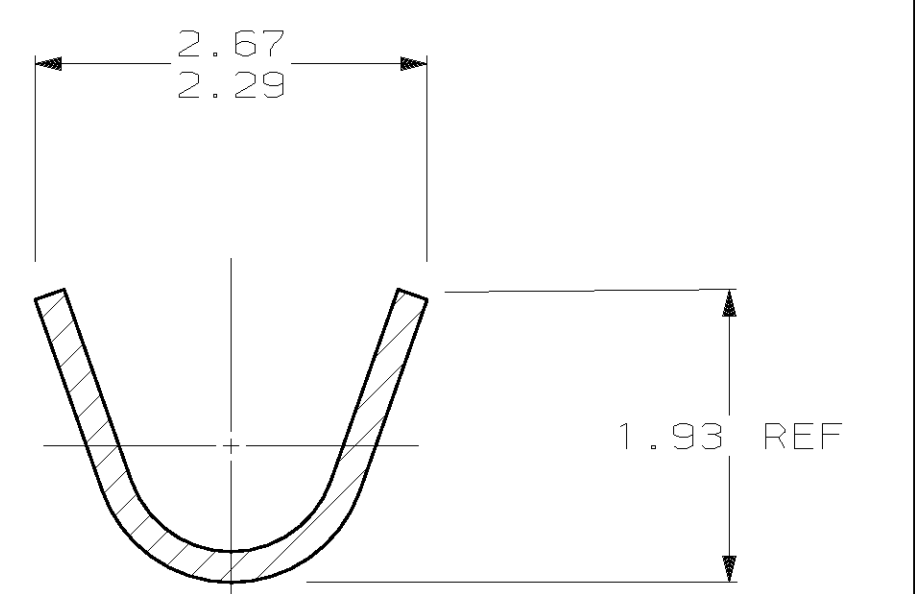
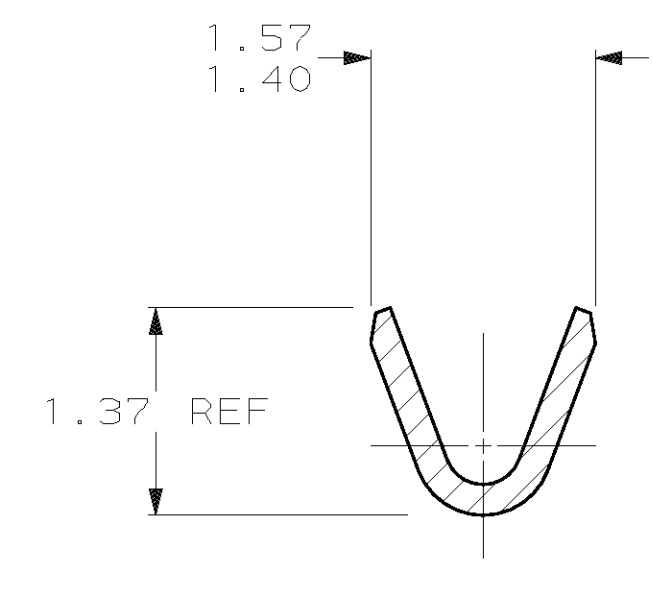
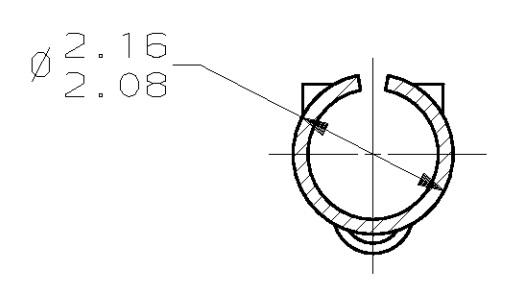
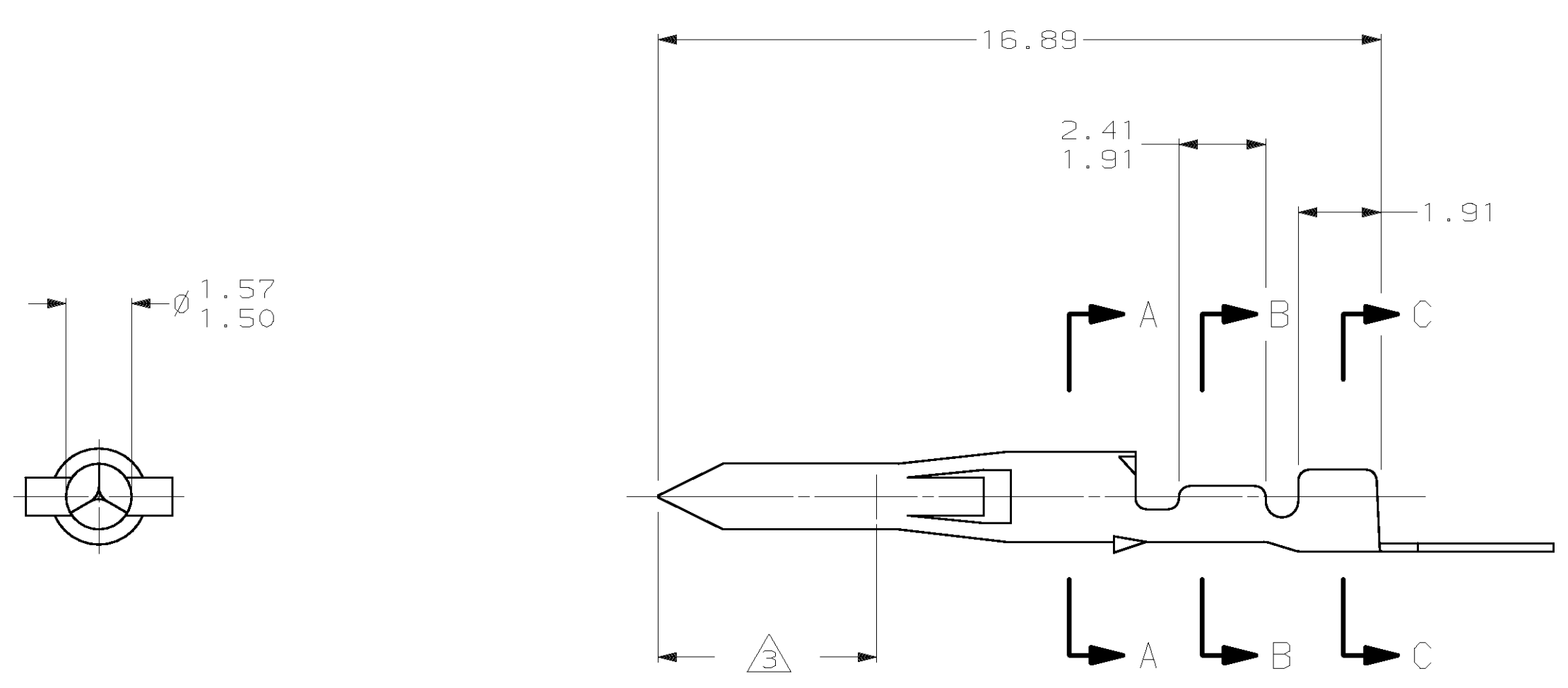

1.57	.062	-	-
1.52	.060	16.89	.665
1.50	.059	5.08	.200
1.40	.055	2.67	.105
1.37	.054	2.41	.095
0.76	.030	2.29	.090
0.20	.008	2.16	.085
0.13	.005	2.08	.082
0.00127	.000050	1.93	.076
0.00076	.000030	1.91	.075
MM	IN	MM	IN

CONVERSION TABLE

FINISH	MATERIAL	INSULATION DIAMETER	WIRE RANGE	PART NO
△	0.20 BRASS	1.52 MAX	0.5 - 0.2 mm ² (30-24 AWG)	640391-5
PRE-TIN	0.20 BRASS	1.52 MAX	0.5 - 0.2 mm ² (30-24 AWG)	640391-1

DO NOT SCALE PRINT.
 UNLESS SPECIFIED
 DIMENSIONS IN mm
 TOLERANCES ON:
 2 PLC DEC ±
 3 PLC DEC ± 0.13
 ANGLES ± -

DR 9-12-90
 B. LEWIS
 CHK 9-13-90
 R. SWING
 APPD 9-27-90
 C. CASH
 APPD 9-27-90
 C. CASH
 PRODUCT SPEC
 -
 APPLICATION SPEC
 -
 WEIGHT -

AMP AMP Incorporated
 Harrisburg, PA 17105-3608
 NAME
 .062 PIN,
 COMMERCIAL PIN AND SOCKET
 SIZE D
 CAGE CODE 00779
 DRAWING NO 640391
 SCALE 8:1
 SHEET 1 OF 1

